



**AVIATION**

# **APPLYING FOR A FLORIDA PRIVATE-USE TEMPORARY AIRPORT SITE APPROVAL ORDER AND AIRPORT REGISTRATION**





# INTRO

Establishing a private-use temporary heliport requires following a specific process detailed in Chapter 14-60, Florida Administrative Code. This document will summarize the process for establishing a private-use temporary heliport. The flow-charts below outline the processes, and the following sections explain the processes in detail. Following the procedure is required to apply for a temporary Airport Site Approval Order and Airport Registration by Chapter 330, Florida Statutes.

## PROCESS MAP FLOW



## NOTICE

*Chapter 120.60, Florida Statutes allows FDOT 90 days to process a complete application for a private-use temporary heliport, however, it typically takes less than 7 days.*

*FDOT’s decision must be noticed in the Florida Administrative Register for 14 days pursuant to Chapter 120.569, Florida Statutes. If a request for administrative hearing is timely filed, the decision is held in abeyance pending the outcome of the administrative process.*

## 1. LOCAL ZONING

Notify the local zoning authority having jurisdiction over the site of your intention to operate a private-use temporary heliport and obtain a statement that the proposed heliport is a compatible land use for the location or that such requirements are not applicable. Also, include a statement that the heliport that you plan to operate complies with local building regulations.





## 2. COMMUNICATIONS

Communication with the following entities is required prior to submitting documentation to the FDOT:

### EXISTING AIRPORTS AND HELIPORTS

Send a letter of notification of your intent to operate a private-use temporary heliport to all VFR airports and heliports within three nautical miles and all IFR airports within 10 nautical miles of the site. Keep a list of the names and mailing addresses as well as a sample copy of the letter of notification. Also, keep a copy of all correspondence in reply.

### PUBLIC OUTREACH

#### Real Property Owners

Send a letter of notification of your intent to operate a private-use temporary heliport to all real property owners within 300 feet of the site perimeter. Keep a list of the names and mailing addresses as well as a sample copy of the letter of notification. Also, keep a copy of all correspondence in reply.

#### Public Notice

Publish notification of your intent to operate a private-use temporary heliport in a newspaper of general circulation in the county in which the proposed site is located and counties within five nautical miles of the proposed site. Keep a copy of the notice and of the letter, showing the recipient's name and mailing address for the newspaper.

### TRAFFIC PATTERNS

Obtain written memorandum(s) of understanding or letter(s) of agreement, signed by each respective party, regarding air traffic pattern separation procedures between the parties representing the proposed private-use temporary heliport and any existing airport(s)/heliport(s) located within three miles of the proposed site.



# 3. SUBMISSION TO FDOT

The following information and documentation must be provided to FDOT by emailing the Aviation Operations Administrator at [david.roberts@dot.state.fl.us](mailto:david.roberts@dot.state.fl.us).

## TEMPORARY HELIPORT DETAILS

- Company Name
- Dates Temporary Heliport will be operated
- Temporary Heliport Physical Address
- Temporary Heliport Latitude
- Temporary Heliport Longitude
- Make and model of the aircraft that will be operating from the site
- The dimensions of the TLOF
- The dimensions of the FATO
- The dimensions of the Safety Area



## PROPERTY RIGHTS

- A copy of written legal confirmation of ownership, option to buy, or lease agreement for the real property that comprises the site on which the proposed temporary private-use heliport would be located.

## FACILITY DIAGRAM

- A scale drawing showing the size and dimensions of the proposed temporary private-use heliport; property rights of way and easements; lighting, power, and telephone poles; location of building(s) on property and surrounding areas; and direction, distance, and height of all structures over 25 feet within 1,000 feet of the site perimeter.

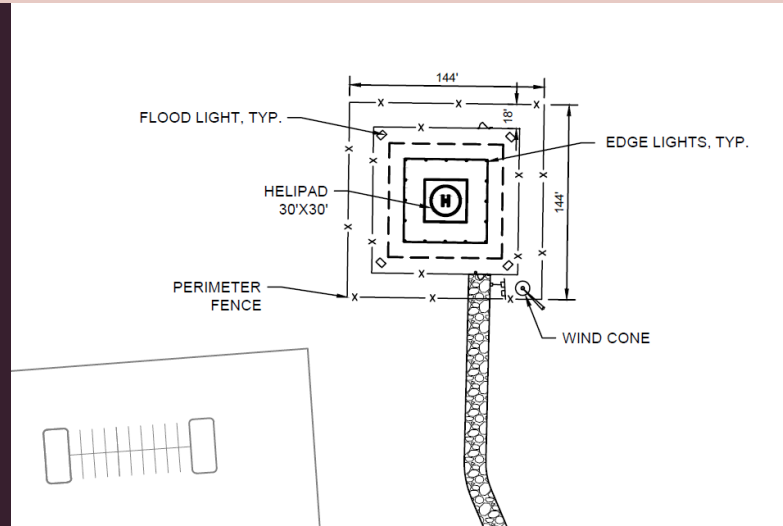

## LOCATION MAP

- A copy of a map or sketch, at least 8.5 x 11 inches in size, showing the location of the proposed temporary private-use heliport site, with respect to recognizable landmarks and access roads to the site clearly marked.

## TRAFFIC PATTERNS

- A written confirmation, including a graphical depiction, demonstrating that safe air traffic patterns can be established for the proposed temporary private-use heliport with all existing airport/heliport sites within three miles of the proposed temporary private-use heliport site and a copy of written memorandum(s) of understanding or letter(s) of agreement, signed by each respective party, regarding air traffic pattern separation procedures between the parties representing the proposed temporary private-use heliport and any existing airport(s)/heliport(s) located within three miles of the proposed site.

## TRAFFIC PATTERN DIAGRAM EXAMPLE

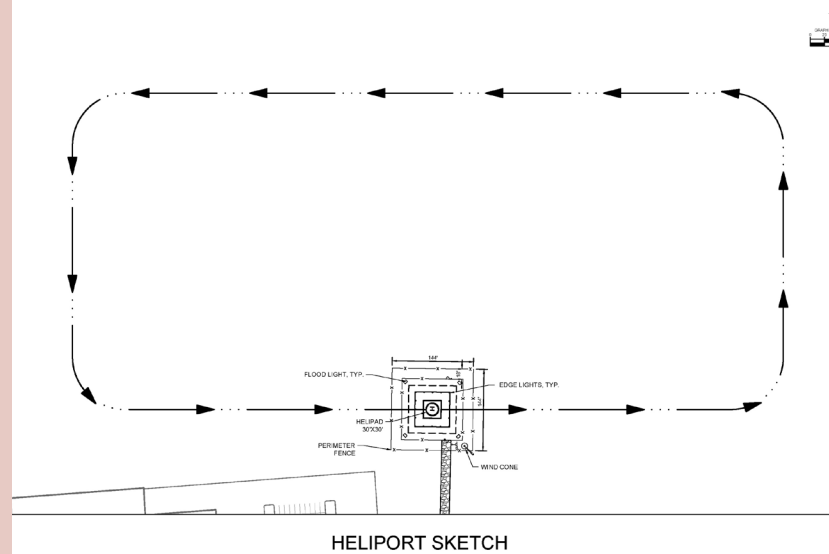

## EXISTING AIRPORTS AND HELIPORTS

- A list of names and mailing addresses for all VFR airports and heliports within three nautical miles and all IFR airports within 10 nautical miles of the site, including a sample copy of the letter submitted as proposal notification to these airports, and attach a copy of all airport reply correspondence.

## REAL PROPERTY OWNERS

- A list of the names and mailing addresses of all real property owners within 300 feet of the proposed temporary private-use heliport site perimeter, including a single copy of the letter of notification submitted as notification to these adjacent real property owners, and include a copy of all real property owner correspondence in reply.

*(If notification was provided by a local government as part of its review and approval process for the heliport, provide written confirmation of the fact, in lieu of the above required submittal by the applicant.)*

## LOCAL ZONING

- A copy of each of the letters of notification, showing the recipient's name and mailing address, that have been submitted to each zoning authority having jurisdiction, for the municipality and county in which the proposed temporary private-use heliport site lies or which is located within five nautical miles of the proposed temporary private-use heliport site and a copy of all related correspondence from each city or county authority, including a statement that the proposed temporary private-use heliport site is in compliance with local zoning requirements or that such requirements are not applicable.

## SAFETY FACTORS

- A written confirmation that the helipad and taxiway design criteria and heliport design layout of the proposed temporary private-use heliport have appropriately taken into account consideration of the manufacturer's performance characteristics for the type(s) of aircraft planned to be operated; the frequency and type(s) of flight operations to be anticipated; planned aviation-related or non-aviation activities on the temporary private-use heliport; and any other safety considerations, as necessary, to help ensure the general public health, safety, and welfare of persons located on or near the airport/heliport.





## SECURITY FACTORS

- A written confirmation that the proposed temporary private-use heliport site owner or lessee will take appropriate steps to help protect the general public health, safety, and welfare through secure heliport operations and that they will develop and implement adequate heliport security measures to safeguard heliport and aviation-related assets from misappropriation or misuse in order to prevent potential loss or public endangerment.



*For a private-use temporary heliport, Airport Registration is issued concurrent with the Airport Site Approval Order and is valid for less than 30 consecutive calendar days and cannot be renewed.*

## REFERENCES

- **Chapter 330 F.S. Regulation of Aircraft, Pilots and Airports**  
[http://www.leg.state.fl.us/Statutes/index.cfm?App\\_mode=Display\\_Statute&URL=0300-0399/0330/0330.html](http://www.leg.state.fl.us/Statutes/index.cfm?App_mode=Display_Statute&URL=0300-0399/0330/0330.html)
- **Chapter 14-60 FAC Airport Licensing, Registration, & Airspace Protection**  
<https://www.flrules.org/gateway/ChapterHome.asp?Chapter=14-60>
- **FAA AC 150/5390-2C Heliport Design**  
[https://www.faa.gov/documentLibrary/media/Advisory\\_Circular/150\\_5390\\_2c.pdf](https://www.faa.gov/documentLibrary/media/Advisory_Circular/150_5390_2c.pdf)



**YOU'RE READY TO FLY!**